

GARAGE DOOR GENERAL MAINTENANCE

Garage doors and electric openers require lubrication every four to six months. Listed below are the recommended types of lubrication. See diagram on the right for critical points that require lubrication.

Acceptable Lubrications

- A. GDL (Garage Door Lubricant)
- B. Light weight oil 10w or less
- C. Lubriplate (White grease)

Non-Acceptable Lubricants

- A. WD 40
- B. Grease of any kind (attracts dirt & compounds problem)
- C. Oils heavier than 10w

Application of Lubricants

- A. Use a 4" plastic directional tube to pinpoint spray
- B. Be careful of over spray on walls and ceiling
- C. Do not spray electric operator T-rails or carriage assembly-oil will drip on cars
- D. Do not lube door tracks

Garage Door Lube Points

- A. Lube steel rollers at joint and lightly on outside perimeter (A). DO NOT LUBE POLY ROLLERS
- B. Lube roller stems to allow free movement (B)
- C. Lube hinges at the point where they pivot (C)
- D. Spray a light coat over the springs- do this when the door is down (D)
- E. Lube bearings at the point where the torsion spring tube passes through the end bearing fixtures, as shown in diagram(E)

Electric Operator Lube Problems

- A. Lube front idler sprocket by the springs (F)
- B. Lube rear sprocket on the top of the machine (G)
- C. Some screw drive operators require white operator grease- Check with manufacturer prior to proceeding

Before applying the grease you must first wipe out the old grease. Then apply a 1/16" bead down the screw. Once you have applied the bead, take your finger across the screw. Cycle the operator and wipe out any excess around the carriage and screw.

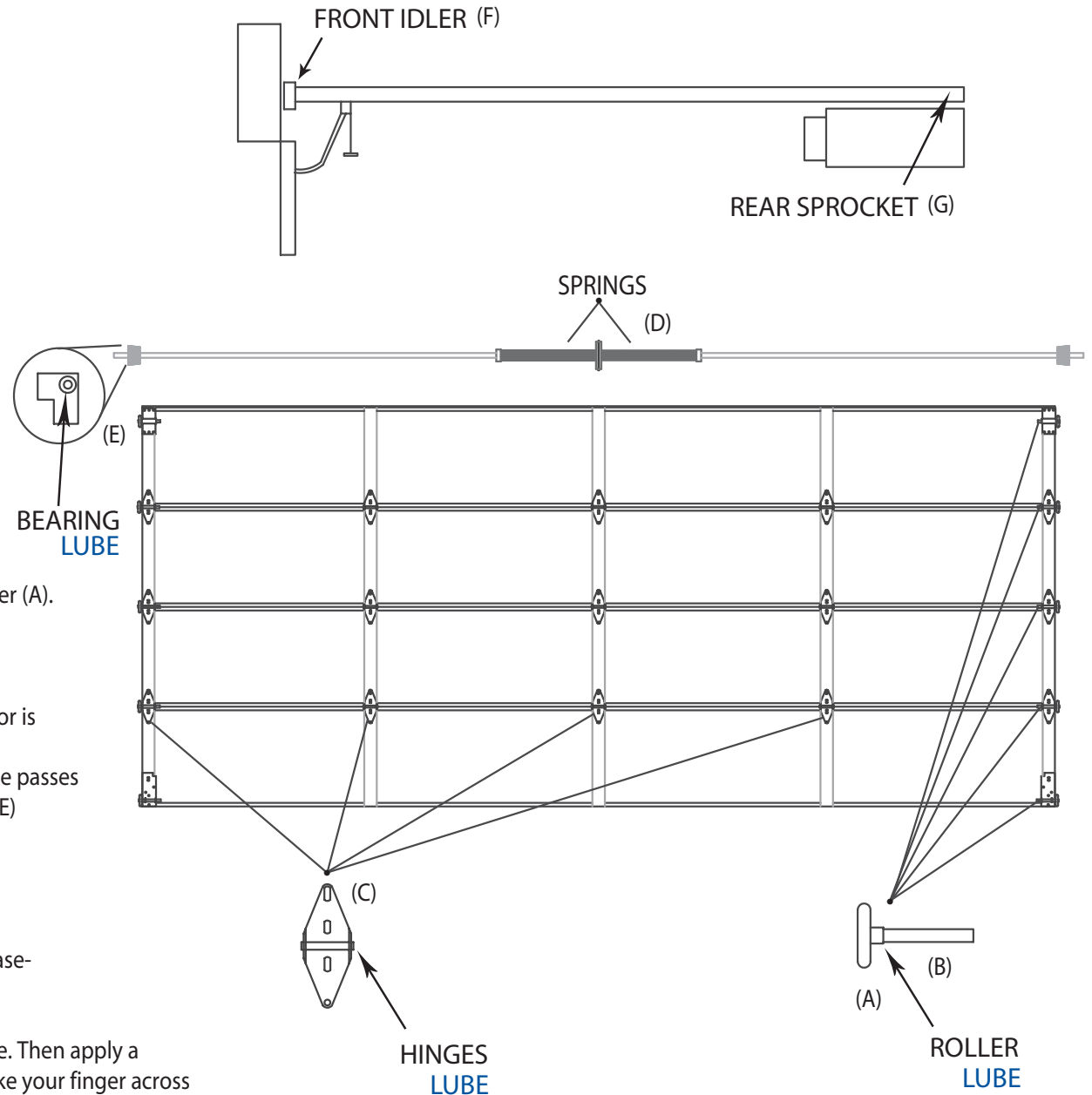

GARAGE DOOR GENERAL MAINTENANCE

GARAGE DOOR PREVENTATIVE MAINTENANCE

Inspect hardware and door at least twice a year for wear, looseness, binding or scraping. If any condition is noticed, or if any impact has occurred, call a professional garage door installer for complete inspection.

All moving parts must be lubricated every four to six months (refer to lubrication recommendations on reverse side). Tighten bolts (wood doors only) twice a year.

Caution: Door is constantly under extreme spring tension. Repair or adjustments to and part or hardware can be very dangerous. Always call a professional garage door installer to perform any such service.

METAL DOORS - INTRODUCTION

Your metal door contains a factory-applied baked-on coating, which has been formulated to prove optimum performance for years with minimal service requirements. Please read thoroughly in order to properly maintain both the protective and aesthetic properties that the coating was designed to provide. These instructions will serve as your guide when you clean, touch-up or repaint your metal door.

CLEANING

To maintain your factory-applied finish so it will last for many years, a minimum routine cleaning at least once a year (or as necessary) is recommended. In most cases, simply washing the door with plain water using a hose or pressure spray will be adequate. However, in areas where dirt collection is heavier or mildew has occurred, the following solution is recommended to remove these build-ups:

- 1/3 cup dry powdered detergent (such as Cheer)
- 2/3 cup tri-sodium phosphate (such as Soilax)
- 1 quart sodium hypochlorite 5% solution (such as Clorox)
- 3 quarts water

Note: It is advisable to use rubber gloves when handling this solution.

A stiff bristle brush may be useful for embossed metal. To minimize streaking, always wash from the bottom to the top. A clean water rinse should follow immediately.

Strong solvents and abrasive type cleaners should be avoided to prevent any permanent damage to the finish. Remove caulk compounds, oil, grease, tars, wax and similar substances with mineral spirits only to those affected areas. Follow with detergent cleaning and clear water rinsing. Be sure to rinse thoroughly.

REPAINTING

If you feel the need to paint your primed metal door or to repaint your finish-coated metal door, be sure to prepare the factory-applies surface as outlined in the cleaning section to the left. New metal doors must be wiped with a mineral spirits soaked cloth to remove waxes present on the surface. Wipe dry with a clean cloth before the mineral spirits dry. Detergent cleaning is not necessary at this point.

Before repainting, make sure all bare metal surfaces are spot primed with a good grade of commercially available primer following the manufacturer's instructions. To achieve maximum repaint adhesion, you may lightly scuff sand the surface with 400 grit sandpaper or fine steel wool. Be sure to remove dust particulate by wiping with a damp cloth. Allow to dry completely.

After the door has been properly prepared, it must be coated within 24 hours with high-quality latex exterior house paint. The paint must be thoroughly mixed before using. Follow the manufacturer's recommendations to reduce the material for spraying.

Apply coatings only when both air and substrate temperatures are above 50° F. Coatings can be sprayed, brushed or roll applied. Spray application is recommended for large surface areas to achieve optimum appearance.

WOOD DOORS

The preparation and painting of your wood garage door is an important part of the finished product. We recommend before installation, the door be lightly sanded and primed with at least one coat of an oil-based primer with tannin block additive. Finish with two coats of high quality exterior paint.

Consult your local paint supplier for products best suited for your area. For other transparent finishes also consult your paint supplier to find quality products to protect the wood and your investment.